

**Modern Equipment
for Modern Geology**

The Standing Desk for Geologists

Fully adjustable core logging tables	3
Optional table components	4-5

Pallet Lifters made for Core Boxes

Robust pallet lifters	6
-----------------------	---

Contacts	7
----------	---

The Standing Desk for Geologists

Fully adjustable core logging table

Adjustable table height from 2'6" – 3'7" (76cm – 110cm) for improved ergonomics

Articulating top from 0° - 40° for preferred logging angle – adjustable maximum for safety

Roller top table for easy core box handling

LED strip lighting for ideal brightness and luminescence

Sizes available – for horizontal logging Canada 2 columns (10ft+) or 3 columns (15ft+) (10-12 and 15-18 boxes)

For vertical logging (US) with 2ft by 1ft boxes (9-14 boxes)

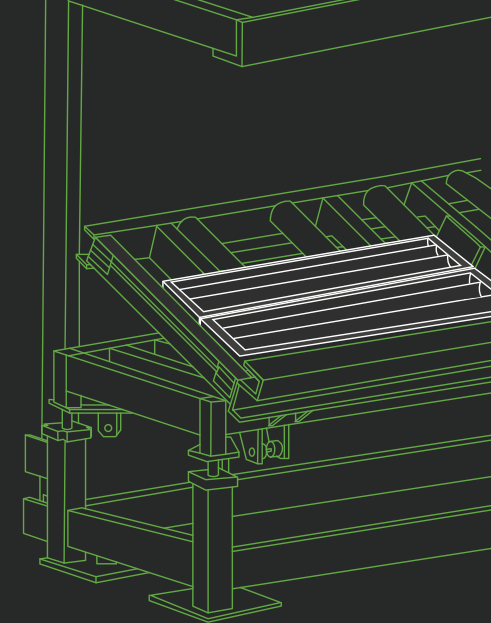

A Quality Robust Product :

Rated load capacity 1,200 lbs - 1,600 lbs (544kg to 680kg), test loaded to 125% capacity

Certified professionally engineered (PEO stamped drawings)

240V twist lock for tight connection and seal

All our equipment are water resistant with all electrical components
UL / CSA - ESA certified

All our products are built in Canada with 3-year warranty

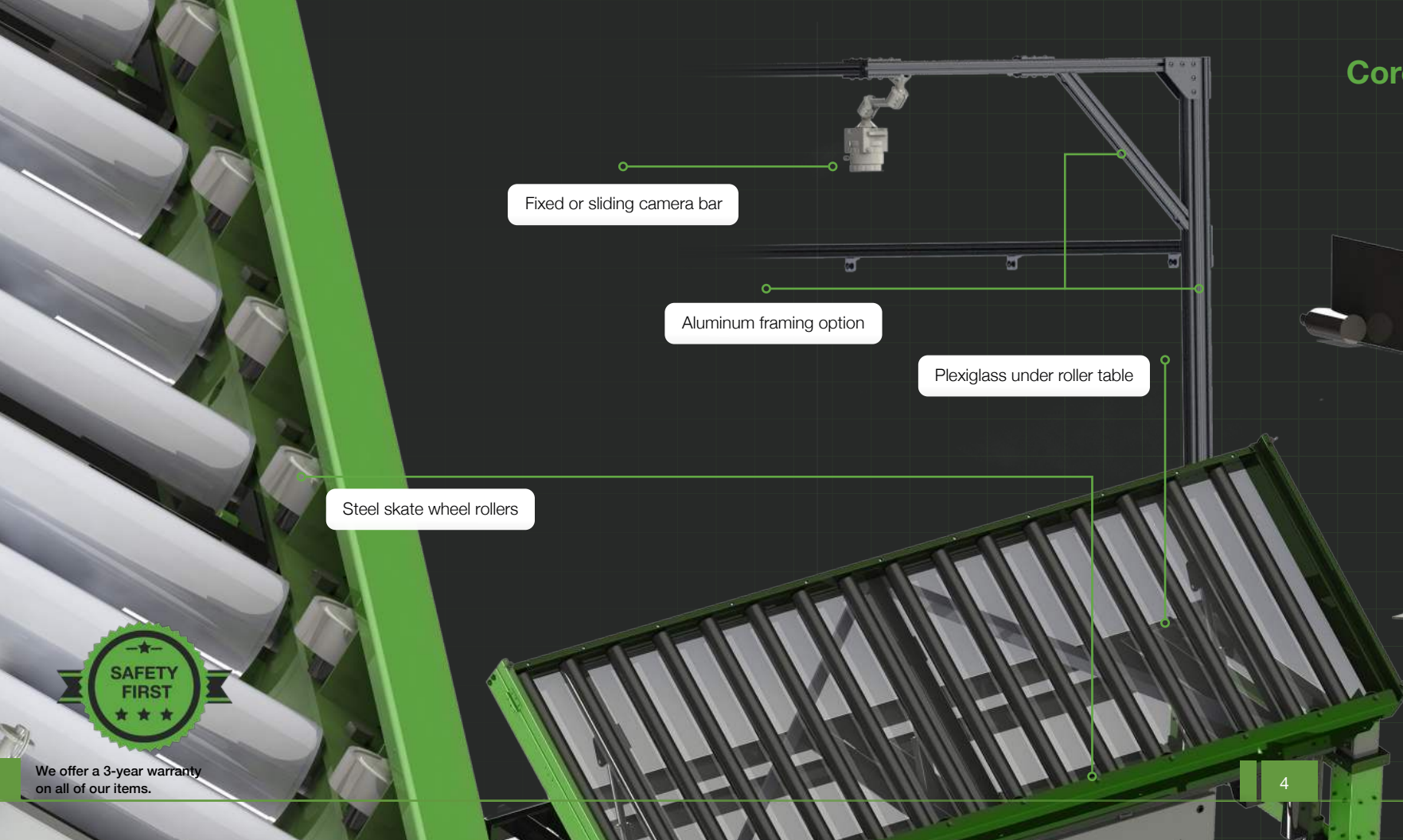

CoreLift optional components



Pallet Lifters made for Core Boxes

Adjustable platform height as low as 8" (21cm) for improved ergonomics and safety

Low profile, push pedal, easy to operate, easy to install (120v standard plug)

Safety features include adjustable maximum height, internal safety velocity fuse, water resistant, sealed dual hydraulics

Optional features such as centering platform, rotating platform, material handling chassis, purity oil, protective curtain...

A Quality Robust product:

Maximum rated capacity 5000 lbs (2270kg), test loaded to 125% capacity

All our equipment are water resistant with all electrical components
UL / CSA - ESA certified

All our products are built in Canada with 3-year warranty

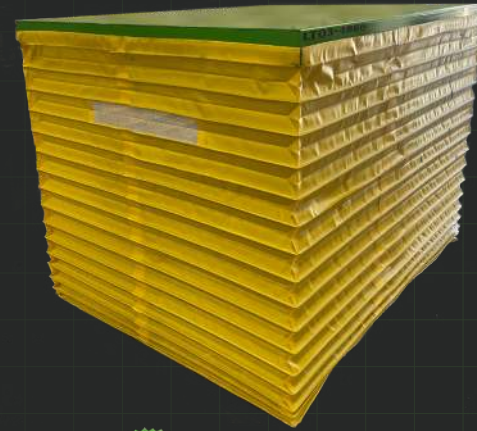

For safety, we recommend a protective curtain

THANK YOU FOR YOUR INTEREST!



Eric Maag

General Manager
CoreLift Inc

If you have any questions regarding our products and services, please feel free to contact us:

+1 (705) 507-8846

www.corelift.ca

Location

6 - 2140 Regent Street
Sudbury, ON P3E 5S8
Canada

Hours

Monday - Friday: 8am - 5pm (EST)

Saturday - Sunday: Closed